



TWO-PHASE

HYBRID STEPPER MOTOR DRIVER

Model: 2L110M

2L110M Summary

2L110M are high performance microstepping drivers incorporating the most advanced technology in the world today. They are suitable for driving any 2-phase and 4-phase hybrid step motors (current 7.8A/3.9A). By using advanced bipolar constant-current chopping technique, they can produce more motor torque at high speed than other drivers. The microstep capability allows stepping motors run at higher smoothness, less vibration and lower noise. The 3-state current control feature leads to lower motor heating.

Applications

Applicable for automated machinery and equipment, for instance, air-driven inscription machines, labeling machines, cutting machines, laser engraving, plotter, medical instruments, and pick-place devices.

Features

- * High performance, low cost, extremely low noise;
- * Both driver and motor low heating;
- * Supply voltage up to 80-220VAC, current output up to 7.8A peak (RMS5.57A);
- * TTL compatible and optically isolated input signals, pulse frequency up to 400 KHz;
- * Automatic idle-current reduction;
- * 16 selectable resolutions in decimal and binary;
- * Suitable for 4,6,8 lead motors;
- * DIP switch current setting with 8 different value;
- * CW/CCW mode available (optional);
- * Over-voltage, short-voltage, over-current, over-heating and short-circuit protection;
- * Suited for NEMA34 and 43 motors.

3. Electrical and Mechanical Specifications

3.1 Electric Specifications ($T_j = 25$) °C

Parameters	2L110M			
	Min.	Typical	Max.	Unit
Output current	0.45	-	7.8	Amps
Supply voltage	80	180	220	VAC
Logic signal current	7	10	16	mA
Pulse input frequency	0	-	400	Khz
Isolation resistance	500	-	-	MΩ

3.2 Mechanical Dimensions (unit = mm, 1 inch = 25.4 mm)

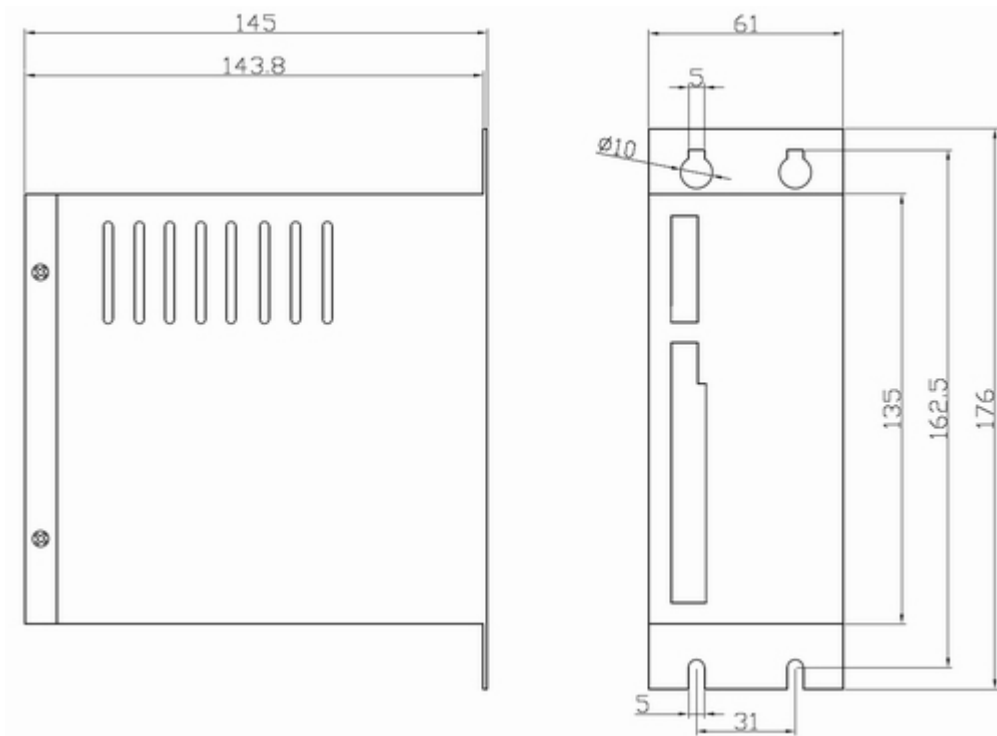

4. Driver Connectors, P1 and P2

Control Signal Connector P1 pins

Pin Function	Details
PUL + (+5V)	Pulse signal: in single pulse(pulse/direction) mode, this input represents pulse signal, effective for each upward-rising edge; in double pulse mode (pulse/pulse) this input represents clockwise(CW)pulse. For reliable response, pulse width should be longer than 1.2us.
PUL- (PUL)	
DIR+ (+5V)	DIR signal: in single-pulse mode, this signal has low/high voltage levels,

DIR- (DIR)	representing two directions of motor rotation; in double-pulse mode (set by SW5), this signal is counter-clock (CCW) pulse, effective on each rising edge. For reliable motion response, direction signal should be sent to driver 5us before the first pulse in the reverse motion direction.
ENA+ (+5V)	<u>Enable signal:</u> this signal is used for enabling/disabling the driver. High level for enabling the driver and low level for disabling the driver. Usually left unconnected(enabled).
ENA- (ENA)	
READY+	Output alarm signal positive: READY is a photocouper output from open-collector circuit, effectively output when driver operate normally, maximum permitted input voltage 30VDC; maximum output current 20mA, generally can be serial connected to PLC input terminal.
READY-	Output alarm signal negative.

Remark 1: SW5 ON means CW/CCW (pulse/pulse), OFF means PUL/DIR mode.

Remark 2: Please note motion direction is also related to motor-driver wiring match. Exchanging the connection of two wires for a coil to the driver will reverse motion direction. (for example, reconnecting motor A+ to driver A- and motor A- to driver A+ will invert motion direction).

Power connector P2 pins

Pin Funtion	Details
AC	AC input, varies from 80V to 220V, recommended to use 180V. (Pis use a transformer as a power, but not directly connect to condition AC.)
AC	
Phase A	Motor coil A (leads A+ and A-)
Phase B	Motor coil B (leads B+ and B-)
PE	Connect ground terminal

5. Setting Driver Output Current and Microstep Resolution

5.1 Current Setting

SW6-9 of the DIP switch are used to set the current during motion (dynamic current)

Peak Current (A)	RMS (A)	SW6	SW7	SW8	SW9
0.45	0.32	OFF	OFF	OFF	OFF
0.63	0.45	OFF	OFF	OFF	ON
1.41	1.00	OFF	OFF	ON	OFF
1.88	1.34	OFF	OFF	ON	ON
2.33	1.66	OFF	ON	OFF	OFF
2.85	2.04	OFF	ON	OFF	ON
3.23	2.31	OFF	ON	ON	OFF
3.75	2.68	OFF	ON	ON	ON
4.26	3.04	ON	OFF	OFF	OFF
4.65	3.32	ON	OFF	OFF	ON
5.18	3.70	ON	OFF	ON	OFF

5.55	3.96	ON	OFF	ON	ON
6.15	4.39	ON	ON	OFF	OFF
6.60	4.71	ON	ON	OFF	ON
7.20	5.14	ON	ON	ON	OFF
7.80	5.57	ON	ON	ON	ON

5.2 Microstep Resolution Selection

Microstep resolution is specified by 1, 2, 3, 4 DIP switches as shown in the following table:

usteps/rev.(1.8°/rev)	SW1	SW2	SW3	SW4
400	ON	ON	ON	ON
500	OFF	ON	ON	ON
600	ON	OFF	ON	ON
800	OFF	OFF	ON	ON
1000	ON	ON	OFF	ON
1200	OFF	ON	OFF	ON
1600	ON	OFF	OFF	ON
2000	OFF	OFF	OFF	ON
2400	ON	ON	ON	OFF
3200	OFF	ON	ON	OFF
4000	ON	OFF	ON	OFF
5000	OFF	OFF	ON	OFF
6000	ON	ON	OFF	OFF
6400	OFF	ON	OFF	OFF
8000	ON	OFF	OFF	OFF
10000	OFF	OFF	OFF	OFF

6. Typical Wiring Diagram

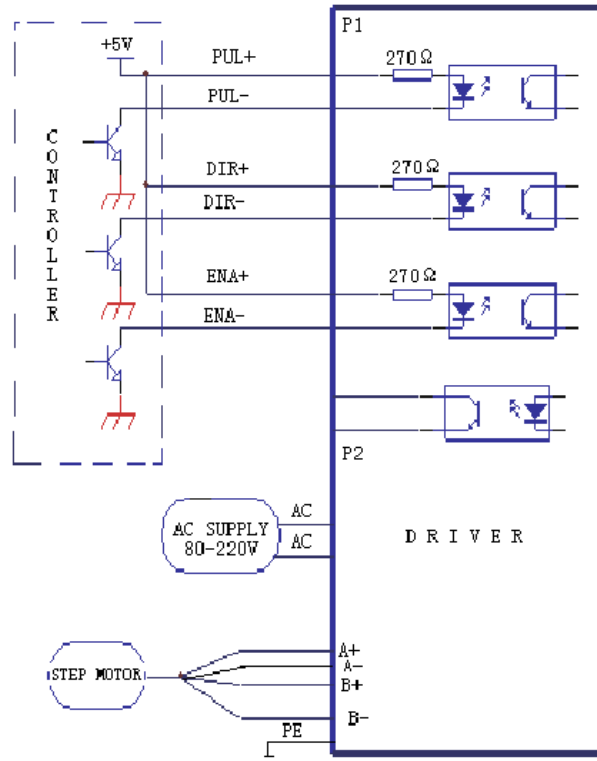

7 Typical Connections

